

High performance

- Mechanical stability 2008.
- European Technical Agreement (ETA-07/0308)



Adaptable and customized solutions

- A versatile structure for constructing partitions with wood or glass panels joined by conventional aluminium trims or a hollow gasket system.



• Usual partition with aluminium trim

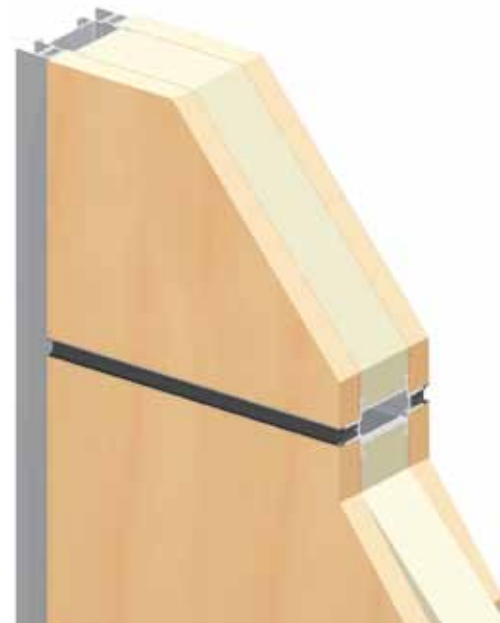

• Partition with hollow gasket



OPALE

PARTITION SYSTEM

- Partition with U rail.
- Partition with narrow rail.
- Partition with hollow gasket system.



Architect: SCI La Scuderia, J. Chabanne
Photographer: S. Demilly



Architect: A. Adlaugary - Photographer: Photo ISO Studio

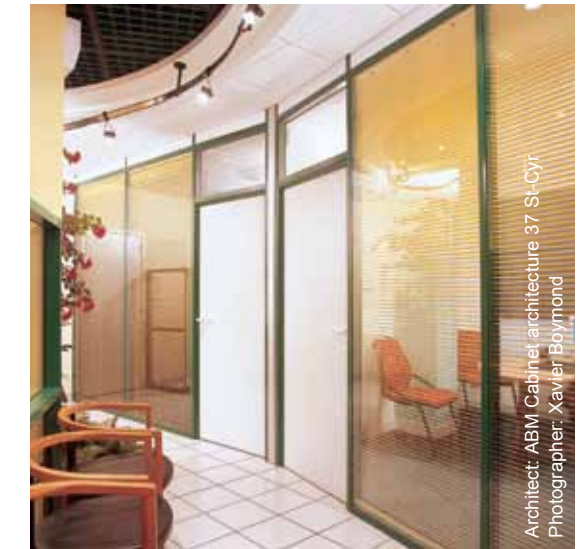

Architect: ABM Cabinet architecture 37 St-Cyr
Photographer: Xavier Boymond



Photographer: Xavier Boymond



Architects: J.-P. Dhaluin et Ph. Peniv - Photographer: P. Loubet

Hydro Building Systems International: 270, rue Léon-Joulin • BP 63709 • 31037 Toulouse cedex 1 • France
Tel.: +33 (0) 561 312 626 • Fax: +33 (0) 561 312 600 • www.technal-int.com

TECHNAL is a Hydro Brand



Partitions



Conventional junction with aluminium trim system

- Customized solutions allowing vertical or horizontal lines to be emphasized using different trim sections.
- Simplicity and high performance:
 - acoustic attenuation of **44 dB**,
 - **CERFF certification n°C.07.412.**

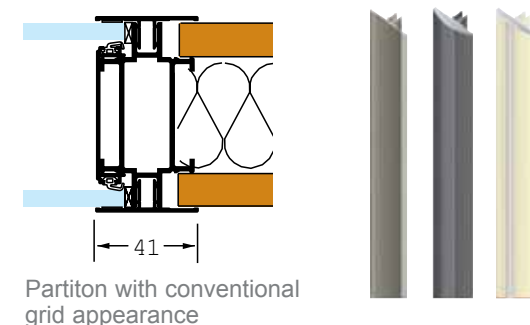

Junction with hollow gasket

(Technal patent)

- Flush wood or glass panels.
- Mixed partition using trims and hollow gaskets.

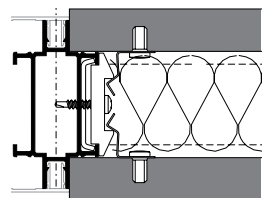

Wood-glass panels joined by hollow gasket



Mixed system

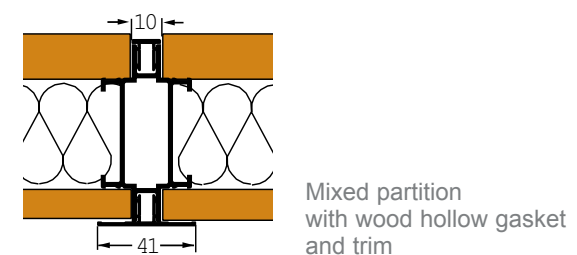

Integration

- Plinth, transom and mullion integrating electrical wiring.
- Manual or power-operated blind.



Plinth



Blind

Doors

Side-hung door

- Same outer frame for all doors.
- Range of ergonomic hinges and handles.
- Different sets for door ready to assemble.

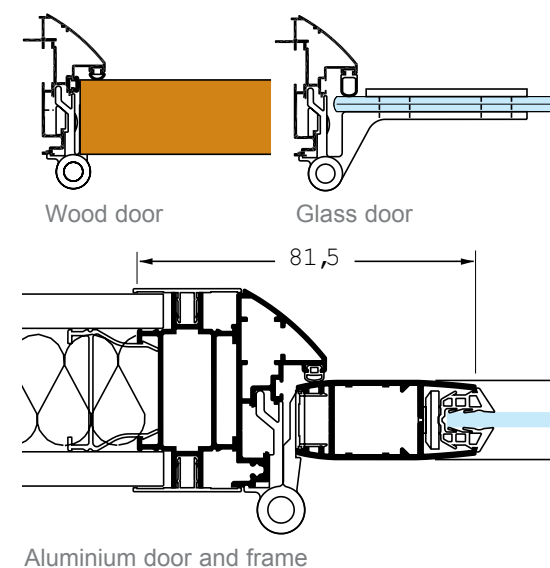
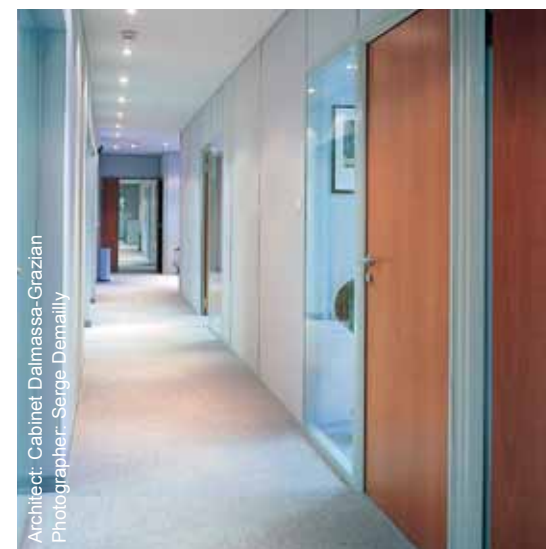

Full-access sliding retractable door

- Opens completely, no rail in ground.
- Accommodates glass or wood infill.



Attractive, high performance

- Leaves up to 3 m high and 1.2 m wide.
- 100 kg max. per leaf.
- Provides full access.
- Easy-to-manoeuvre pull handle and optional lock.

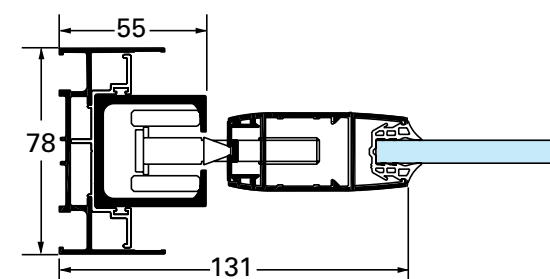

Full-access door

Partition with U rail

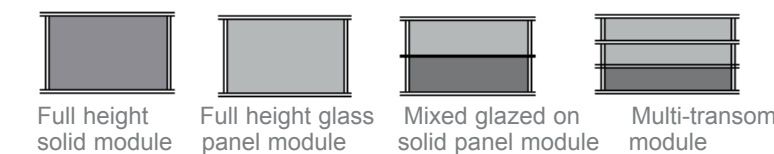

Partition with narrow rail

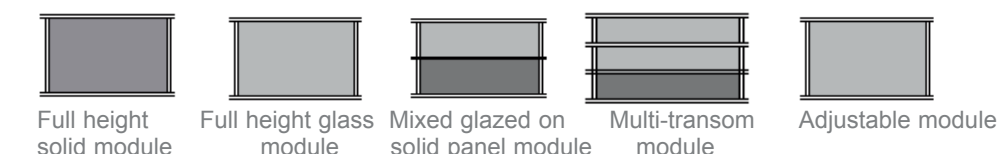

Partition with hollow gasket system

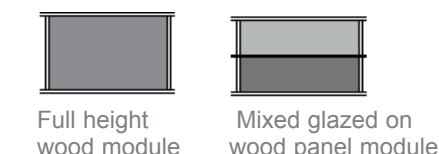

Side-hung doors



Full-access sliding doors

